

Seat No. **OCT-NOV 2025 WINTER EXAMINATION****11731 Bachelor of Technology (NEP-2.0)****Sub. Name: Engineering Graphics****Sub. Code: 108719****Day and Date: Monday ,02-02-2026****Total Marks: 60****Time: 10:30 AM To 01:30 PM****Instructions: 1. All questions are compulsory  
2. Assume suitable data wherever necessary and mention it boldly****Special Inst.: All dimensions are in MM****Q1) Solve any three [18]**

- a.** Construct the parabola when base is 110 mm and height 50 mm with the help of rectangle method. **[6]**
- b.** Line PQ 75 mm long, inclined at  $55^\circ$  to the HP and parallel to VP. Its end A is at 35 mm from both planes, draw its projections. **[6]**
- c.** A hexagonal lamina of side 35 mm is resting on one of its sides on VP such that its surface is inclined at  $40^\circ$  to the VP, draw its projections. **[6]**
- d.** A cone of base diameter 60 mm and height 90 mm is resting on one of the points of circumference of base on HP. Draw its projections if its axis is inclined at  $40^\circ$  to the HP. **[6]**

**Q2) Solve any one [18]**

- a.** Using First Angle Projection Method draw – (a)Front View (b) Top View & (c) Right Hand Side View for the following object. **[18]**

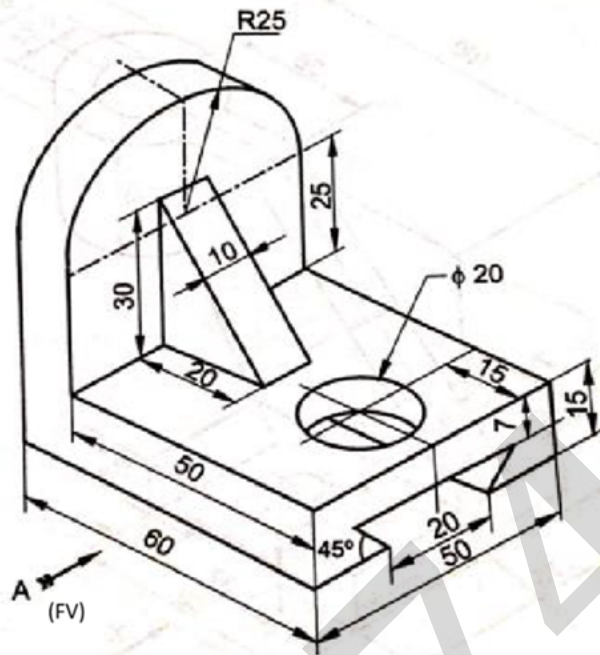

- b. Using First Angle Projection Method draw – (a)Front View (b) Top View & (c) [18] Left Hand Side View for the following object.

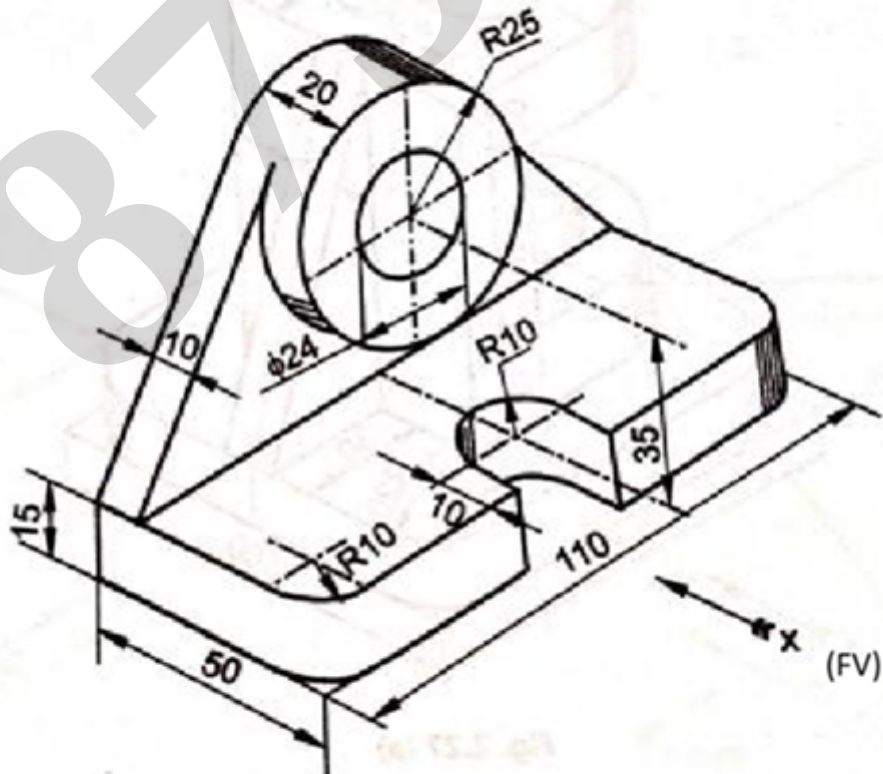

Q3) Solve any one

[12]

a. F.V. and T.V. of an object are given. Draw it's isometric view.

[12]

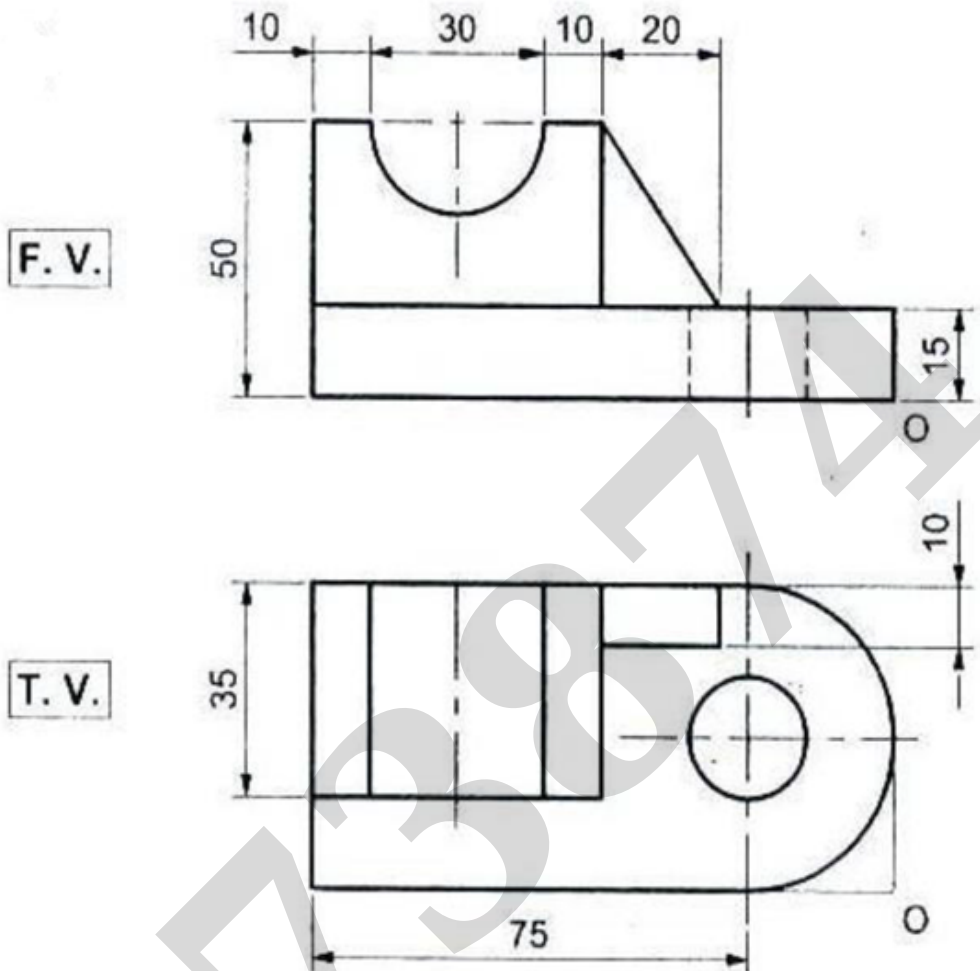

b. F.V., T.V. and S. V. of an object are given. Draw it's isometric view.

[12]

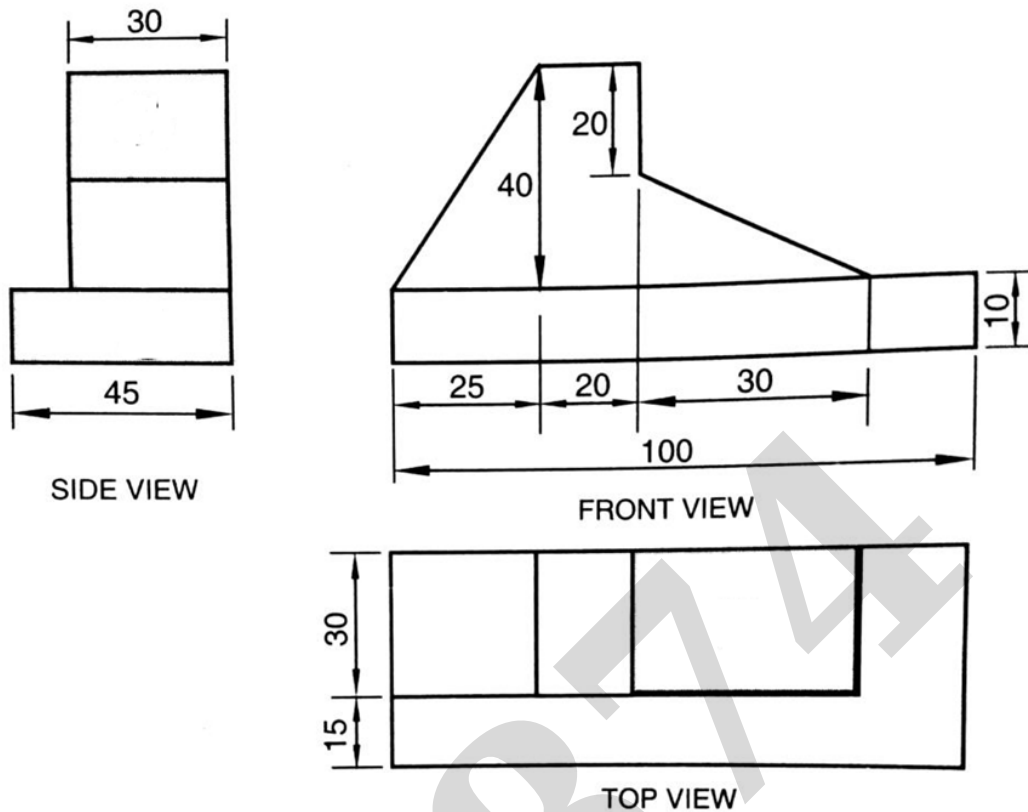

Q4) Solve any two

[12]

- a. A square prism with base side 35 mm and height 70 mm rests on its base on HP. It is cut by a plane inclined at  $30^\circ$  to HP passing through bisecting the axis. Develop the lateral surfaces. [6]
- b. A pentagonal pyramid with base side 28 mm and axis length 68 mm rests on HP. It is cut by a plane inclined at  $55^\circ$  to HP passing through a base corner. Draw the development of the lateral surface. [6]
- c. A right circular cone of diameter 55 mm and height 80 mm rests on its base on HP. It is cut by a plane inclined at  $30^\circ$  to HP passing through a point on the axis 35 mm from the apex. Draw the development of the lateral surface. [6]

## End Of Question Paper

**Important Note for Chief Exam Officer / SRPD Coordinator / Sr Supervisor/ Student -**

This Question Paper may be distributed for following Subjects as common code.

सदरची प्रश्नपत्रिका खालील विषयांकरिता वितरित करता येईल.

1] (11731) Bachelor of Technology (NEP-2.0) (108719) Engineering Graphics Part 1 SEM 1