

Seat No. **OCT-NOV 2025 WINTER EXAMINATION****12609 Bachelor of Technology (NEP-2.1)****Sub. Name: Engineering Graphics****Sub. Code: 114849****Day and Date: Monday ,02-02-2026****Total Marks: 60****Time: 10:30 AM To 01:00 PM****Instructions:** 1. Drawings must be drawn to the given scale
2. Figures to the right indicate full marks**Special Inst.:** 1. Question no 1 is Compulsory
2. Solve any Three from Q 2, 3, 4, 5**Q1)** Solve following MCQ.**[6]**

- i. The eccentricity of a hyperbola is:
A. Less than 1
B. Equal to 1
C. Greater than 1
D. Zero
- ii. If a plane is parallel to VP, its front view shows:
A. True shape
B. Line
C. Point
D. Apparent shape
- iii. A cone's axis inclined to HP and parallel to VP will show an ellipse in:
A. Front view
B. Top view
C. Side view
D. Auxiliary view
- iv. The minimum number of principal views normally used are:
A. One
B. Two
C. Three
D. Four
- v. Isometric view of a rectangle is a
A. rhombus
B. square
C. rectangle
D. parallelogram

- vi. The development of a cone's lateral surface is:
- A. A sector of a circle
 - B. A rectangle
 - C. A trapezoid
 - D. A triangle

Q2) Solve **[18]**

- a. Construct a Hyperbola by point method when P is [30,40] **[6]**
- b. Line AB 70 mm long, inclined at 45° to the VP and parallel to HP. Its end A is at 25 mm above HP and 30 mm in front of VP, draw its projections. **[6]**
- c. Pentagon of side 30mm resting on one of its edge parallel to VP. Draw its Projection. **[6]**

Q3) Solve **[18]**

- a. A cone of base Diameter 50 mm and Height 70mm is resting on H.P. on the point of the base of cone makes 60 degrees to H.P. Draw its Projection **[6]**
- b. Draw Front View and Top View. **[12]**

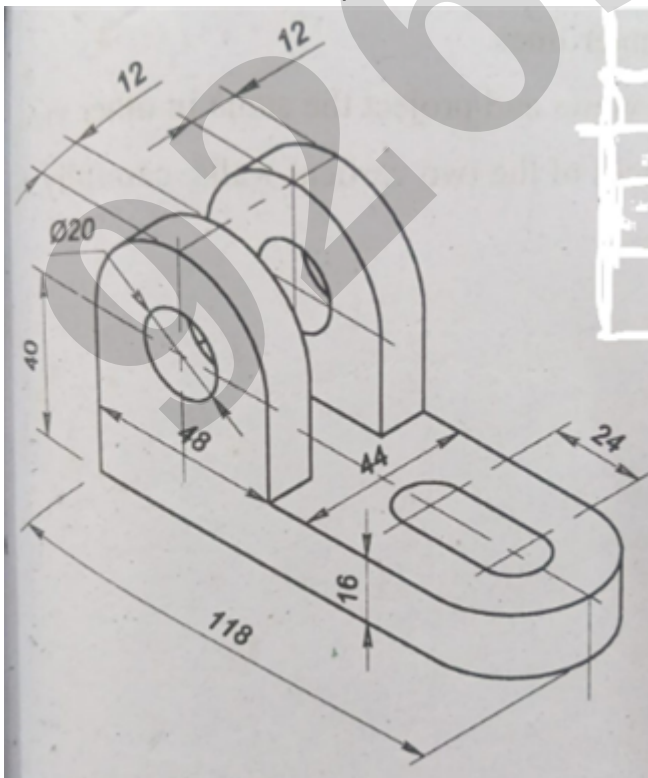

Q4) Solve **[18]**

- a. A cylinder of base dia. 40mm and axis height 70mm is resting on HP on its base. It is cut by section plane inclined at 30degrees to HP. perpendicular to **[6]**

VP and Passing through the center of the axis. Draw the development of it.

b. Draw the Isometric projection

[12]

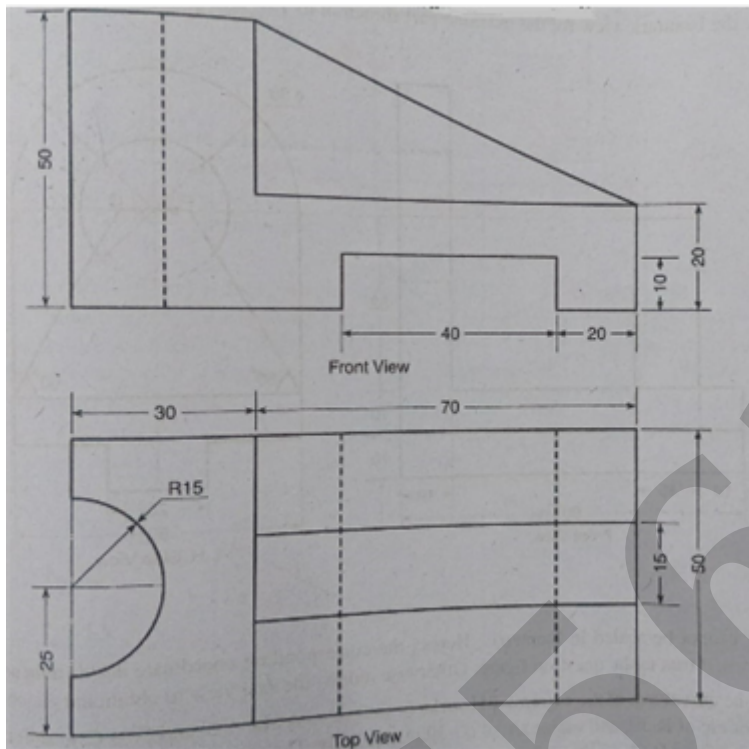

Q5) [18]

- a. Draw the Parabola with base length 100mm and Height of axis 75mm [6]
- b. A hexagonal pyramid side of base 40 mm and axis height 60 mm resting on HP with one of its base side is parallel to VP. The axis of solid is inclined to HP at an angle of 30 degree. Draw the Projection. [6]
- c. A pentagonal prism of side 45 mm and axis length 110 mm is resting on HP with one of its side of base is perpendicular to VP and it is cut by an auxiliary inclined plane inclined at 40° to the HP and passing through top left corner of the prism. Develop the lateral surface of prism [6]

End Of Question Paper

Important Note for Chief Exam Officer / SRPD Coordinator / Sr Supervisor/ Student -

This Question Paper may be distributed for following Subjects as common code.

सदरची प्रश्नपत्रिका खालील विषयांकरिता वितरित करता येईल.

1] (12609) Bachelor of Technology (NEP-2.1) (114849) Engineering Graphics Part 1 SEM 1